

**DESIGNED TO GO  
THE EXTRA MILE.**

**JUST LIKE OUR  
LUBRICANT SOLUTIONS  
FOR TRUCK FLEETS.**

**DESIGNED TO MEET CHALLENGES**



## CHOOSING THE RIGHT LUBRICANTS AND SERVICES FOR YOUR BUSINESS NEEDS CAN HELP TO MAKE A REAL DIFFERENCE TO YOUR ENTIRE OPERATION.

### DESIGNED TO IMPROVE PROFITABILITY

Keeping your trucks on the road and running efficiently can be critical for a profitable business. At Shell lubricants, we appreciate that to be competitive you need your vehicles to be reliable to increase their availability and to protect your investment while reducing operating costs and complying with environmental standards. Choosing the right lubricants and services for your business needs can help to make a real difference to your entire operation.

Our technology-leading heavy-duty-truck lubricants, which are developed, researched and supported by our international team, can help you to reduce your operating and equipment-ownership costs by providing

- enhanced protection of critical components to extend vehicle life
- reduced lubricant consumption through extended-life products
- improved efficiency through synthetic oil technology.

### UNDERSTANDING YOUR NEEDS

Because of our experience of working with long- and short-haul truck fleets across the world, we understand the crucial role that lubricants play in your vehicles. Whether you want to cut the cost-per-kilometre of your long-haul operations by reducing fuel consumption or to extend short-haul-vehicle life under severe start-stop driving conditions, we have a wide range of products to choose from.

Our international network of experts can design a package of products and services that aim to meet your specific needs and to help increase your profitability. Not only do we supply an extensive range of lubricants, we also aim to help you to

- choose the right products
- store and apply your lubricants correctly
- achieve continuous improvement through vehicle and performance monitoring.



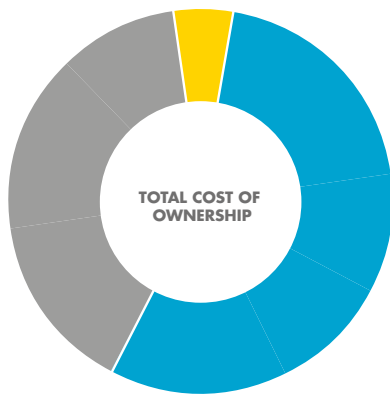

**PRODUCT COSTS**  
Lubricants



**MAINTENANCE COSTS**  
Leaks  
Handling and dispensing  
Oil analysis  
Disposal



**BUSINESS COSTS**  
Inventory  
Administration and management  
Training

### LUBRICANTS – SMALL COST, BIG IMPACT

Buying low-quality lubricants can be a false economy. Lubricant costs are typically less than 5% of a fleet's total maintenance budget. We focus on providing performance products that can help to reduce maintenance requirements and fuel consumption, and services that are designed to improve maintenance and business practices, and thus lower your overall costs.



### DELIVERING VALUE

By designing the right package of lubricants and services for your requirements, we can help you to significantly reduce your total operating and vehicle-ownership costs. Using high-quality, appropriate lubricants and services correctly can help lower fuel and maintenance costs, extend vehicle life and increase vehicle availability.

### LOCALLY SUPPORTED INTERNATIONAL PRODUCTS AND SERVICES

Our international organisation of lubrication experts based across the world means that we can deliver lubricants with proven performance and multiple equipment manufacturer approvals wherever you operate. Our experts can work with you to analyse your needs and solve your problems. They can provide and help to implement a lubrication plan designed to unlock your fleet's potential.

We offer a wide range of lubricant-related services to help you maximise the positive impact of lubricants on your operation. These services can include

- **Shell LubeAdvisor** lubricant surveys and recommendations
- **Shell LubeVideoCheck** engine inspection
- **Shell LubeAnalyst** oil condition monitoring.

For example, the Shell LubeAnalyst service can be a vital tool in extending vehicle life and the time between services. This health check for lubricants and vehicle components is designed to reduce costs and add value by

- identifying potential oil contamination or component failures before they become critical
- extending lubricant life, thus reducing change-out downtimes and procurement costs
- reducing risks and contributing to safe and reliable operations.





## WORKING WITH THE TRANSPORT INDUSTRY

Because lubricants are critical truck components, we work with equipment manufacturers to make sure that our products help to enhance fuel efficiency and offer increased protection and extended oil and equipment life.

We have long-standing relationships with many of the leading truck manufacturers. Many of these companies supply their trucks containing a Shell lubricant as an essential component of the machine.

We have over 3,000 cases where our lubricants are approved by or meet the specifications of equipment manufacturers. This includes truck manufacturers and component suppliers such as

- Cummins
- Mercedes-Benz
- Detroit Diesel
- Scania
- MAN
- Volvo.

We support the development of new industry performance specifications by working with international organisations such as

- ACEA
- API
- JASO.

## EFFICIENCY FOR YOUR FLEET

Over many years of working with the world's leading long- and short-haul fleet operators, our lubricants experts have developed a deep understanding of your business challenges. We can use our knowledge and experience to create a lubrication plan for your business and tailor our technology-leading products and services to help you meet the needs of your business.

Challenge us to demonstrate how we can add value to your fleet operations by **contacting your local Shell Lubricants customer service centre.**



[shell.com/fleets](https://www.shell.com/fleets)

"Shell Lubricants" refers to the various Shell companies engaged in the lubricants business.

<sup>1</sup>Actual fuel savings may vary, depending on the application, the current oil used, the maintenance procedures and the condition of the vehicle.

<sup>2</sup>Savings reported by individual customers. Actual savings may vary, depending on the application, the current oil used, the maintenance procedures and the condition of the equipment.

## WHERE LUBRICANTS CAN ADD VALUE

Some examples of ways that lubricants can help your operation run more efficiently

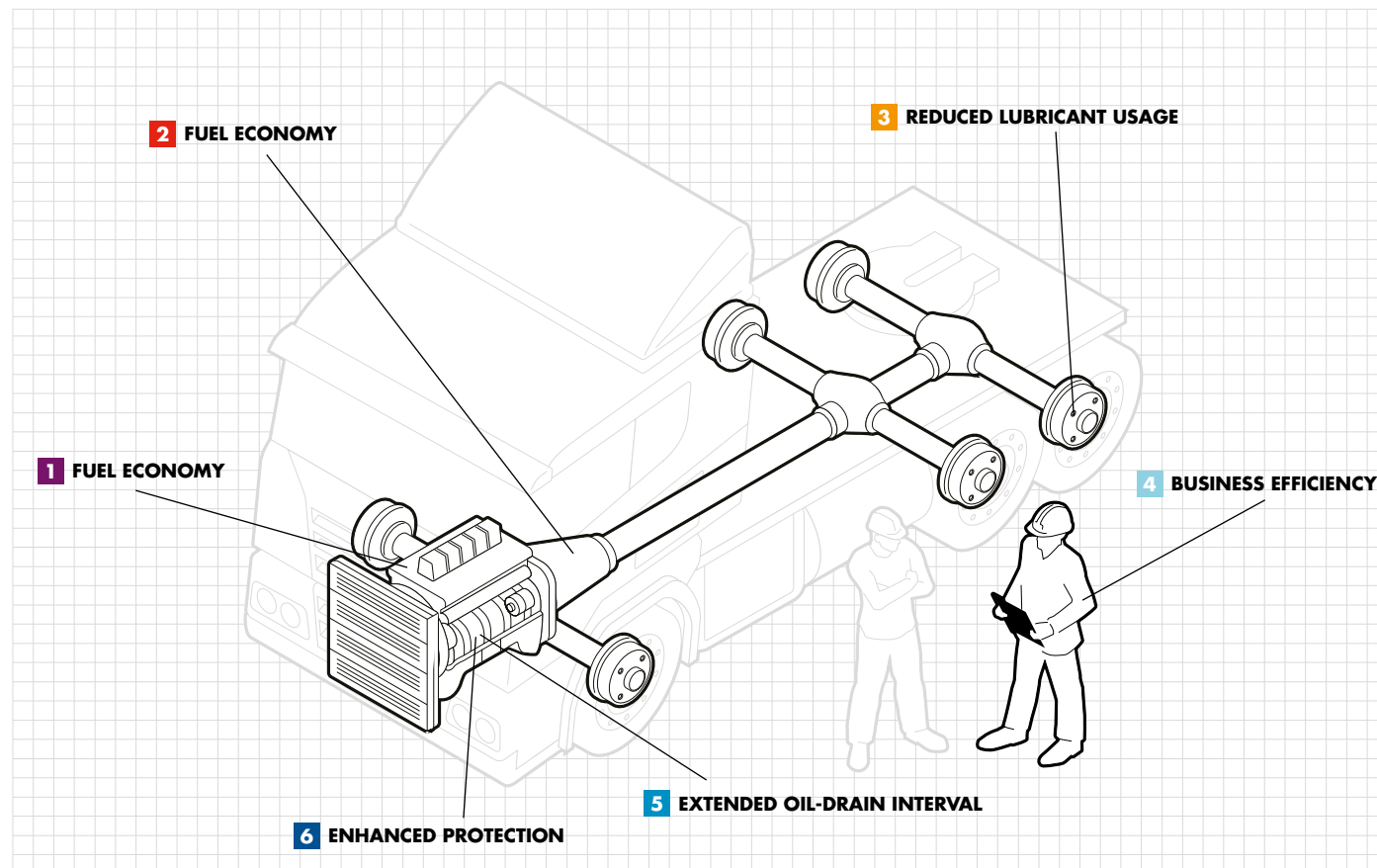

**1 FUEL ECONOMY** with premium Shell Rimula engine oils to give up to 1.1% fuel savings<sup>1</sup>

**2 FUEL ECONOMY** with premium Shell Spirax axle and gear oils to give up to 1.5% fuel savings<sup>1</sup>

**3 REDUCED LUBRICANT USAGE** through extended service life with products such as Shell Gadus greases

**4 BUSINESS EFFICIENCY** for around 50% savings in administration time when moving to a single lubricants supplier from several

**5 EXTENDED OIL-DRAIN INTERVAL** with synthetic Shell Rimula oils

**6 ENHANCED PROTECTION** with Shell Rimula engine oils to reduce wear by 20–50%

### TECHNOLOGY WORKING FOR YOU

The development and application of innovative technology sit at the heart of everything we do at Shell. We invest in cutting-edge laboratories in Asia, Europe and the USA and recruit top-class scientists.

They are the people who develop products that make a difference to your business, even under the most challenging conditions. From the Panama Canal and the Airbus A380 to Ferrari, what we learn in our collaborations, we use to create lubricant solutions to fulfil your business needs.

And we do not just have some of the best lubricants, we also have some of the world's leading field experts working with customers every day to apply these solutions. The result? Technology that delivers value to your operation.

**ENHANCED EFFICIENCY:** Rising fuel costs are a major concern for many customers. One fleet operator reported combined 2%<sup>2</sup> reductions in fuel consumption by switching to premium Shell Rimula engine oils and Shell Spirax gear and axle oils.

**EXTENDED OIL LIFE:** Keeping their trucks on the road is a major objective for many businesses. In one case, a food company wanted to increase its trucks' availability and to reduce maintenance costs by extending oil-drain intervals. It was already using a high-quality oil, but upgrading to Shell Rimula R5 E engine oil increased the oil-drain interval by 130%, which is reducing oil consumption and cutting filter and labour costs.<sup>2</sup>

**A LUBRICATION PLAN DESIGNED TO UNLOCK  
YOUR FLEET'S POTENTIAL**

